

eazypod™



Installation & Operating Instructions

Note: Please read this manual thoroughly before installation and operation

Thank you for purchasing your new EazyPod™ filter. We are sure you will be delighted with its performance. If you are unsure about anything, please consult your Evolution Aqua dealer or contact us.

The EazyPod filtration unit has been designed on the principles of high performance, minimum maintenance and a compact footprint. This design delivers optimum water quality by using **Kaldnes K1 media**. The concept of the EazyPod is based on the world renowned Nexus Eazy system - please visit our website for more information - www.evolutionaqua.com.

EazyPod Overview:

The concept is simple and yet innovative. Water enters via the inlet **A** (fig.1) and enters the outer chamber **B**, which runs around the entire circumference of the EazyPod. Between **B** and the central chamber **C**, is a stainless steel perforated screen. These perforations are situated in the lower half of the screen and around its entire face. This means that when the water passes from the outer to inner chamber (**B** to **C**), a downward flow is created. This causes many of the larger solids to settle in the base of the outer chamber, due to the force of gravity.

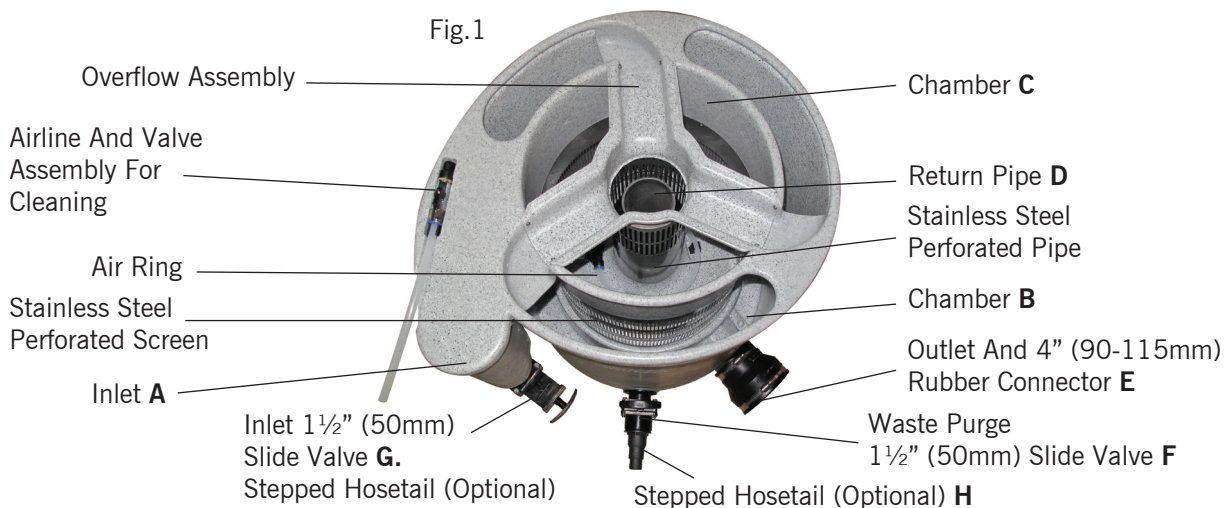

The size of the perforations will not allow large mechanical waste to enter the central chamber, thus acting as a first stage mechanical filter. The central chamber holds **30 litres** of static K1 media. As the water enters the central chamber, the fine smaller solids become entrapped in the K1. After passing through the K1 media, the clean water then rises and overflows into the inner return pipe **D** of the EazyPod. From here it returns to the pond via the return outlet **E**.

The EazyPod filtration system gives water quality and clarity that surpasses all expectations. The nature and volume of the K1 media means, that when static, apart from being a very efficient mechanical filter, there is more than enough surface area for beneficial bacteria to colonise. Therefore on a smaller pond, the Pod is an excellent complete filter.

Please note that in normal running, the K1 has to be static – it is only moved during cleaning and maintenance. If the K1 is moved in normal operation, whether by air or by hand, all of the debris it has collected will be returned to the pond! The K1 is cleaned and moved by connecting an air pump to the air line in the Pod, which in turn goes to an air ring in the base of chamber **C**. This has small holes which cause the K1 to move and therefore clean itself.

During the cleaning cycle, the finer particles escape into chamber **B** from the K1. This waste water can then be dumped via a 1.5 inch / 50mm slide valve **F**.

Please check the table opposite to make sure you run your EazyPod within the specified limits to achieve best results.

EazyPod Installation & Operating Instructions

The EazyPod is truly multi-functional. It can be run in several different ways for different applications.

The EazyPod can be used:

- as a complete filter on a quarantine system
- as a pre-filter at the front of any new or existing system
- as a polisher at the end of any system
- off a mid water feed to aid mechanical filtration
- on a skimmer line as a mechanical filter

Remember that if you use the Pod solely as a mechanical filter, you will also get an enhanced biological benefit in your system.

EazyPod Specifications and Flow Rates

Follow this manual carefully and your filter will provide a perfect environment for your fish. One of the factors that can have a significant influence on our ponds is the **turn over** rate. This is the time that it takes for the total water volume of the pond to pass through the filter system once. On EazyPod ponds, where it is used as the only filtration system, a total pond volume turn over of every 1 to 2 hours is required.

Therefore if you have a 10,000 litre koi pond, a minimum rate of 5,000 litres per hour is needed giving a 2 hour turnover, although you could also run at 10,000 litres per hour giving a turnover rate of once per hour.

On an ornamental pond of 20,000 litres, 10,000 litres per hour is the maximum flow rate and is ideal for that size and type of pond. The lower the flow rate you use, the better the performance will be - as long as it **does not** result in a turn over rate of more than two hours.

Max flow rate:	10,000 litres/hr	2,200 UK gallons/hr	2,640 US gallons/hr
Max koi pond size:	10,000 litres	2,200 UK gallons	2,666 US gallons
Max ornamental pond size (goldfish, shubumkins etc):	20,000 litres	4,400 UK gallons	5,333 US gallons
Kaldnes K1	30 litres		
Max feed rate	100 - 120g per day		
Recommended AirPump	EA Airpump 70 or EA Airpump 75		

On opening your EazyPod you will find the following;



Cleaning Pipe



Bag of Kaldnes K1
30 Litres



EazyPod Lid



2 x Slide Valves
Pre-installed



4" to 3"
EazyConnector



2 x Stepped 1½"
Hosetail with
O-Ring

Installation - PLEASE NOTE: EazyPod comes set-up for a Pump Fed Installation.

The EazyPod filtration system can be set up in two ways, **pump** or **gravity** fed. In fig. 2 you can see a typical set-up of a pump fed system, followed by a gravity fed system in fig. 3.

Figure 2. Pump Fed System: (water pumped from pond to filter)

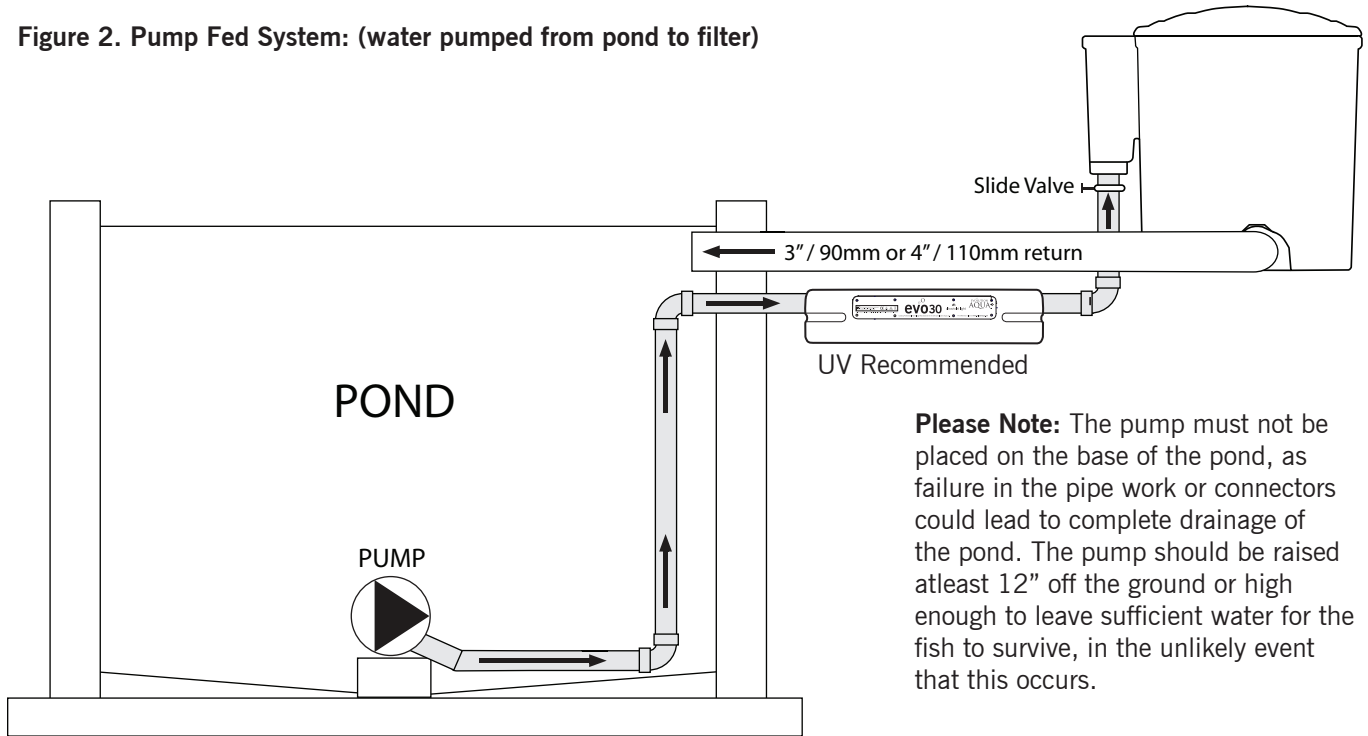
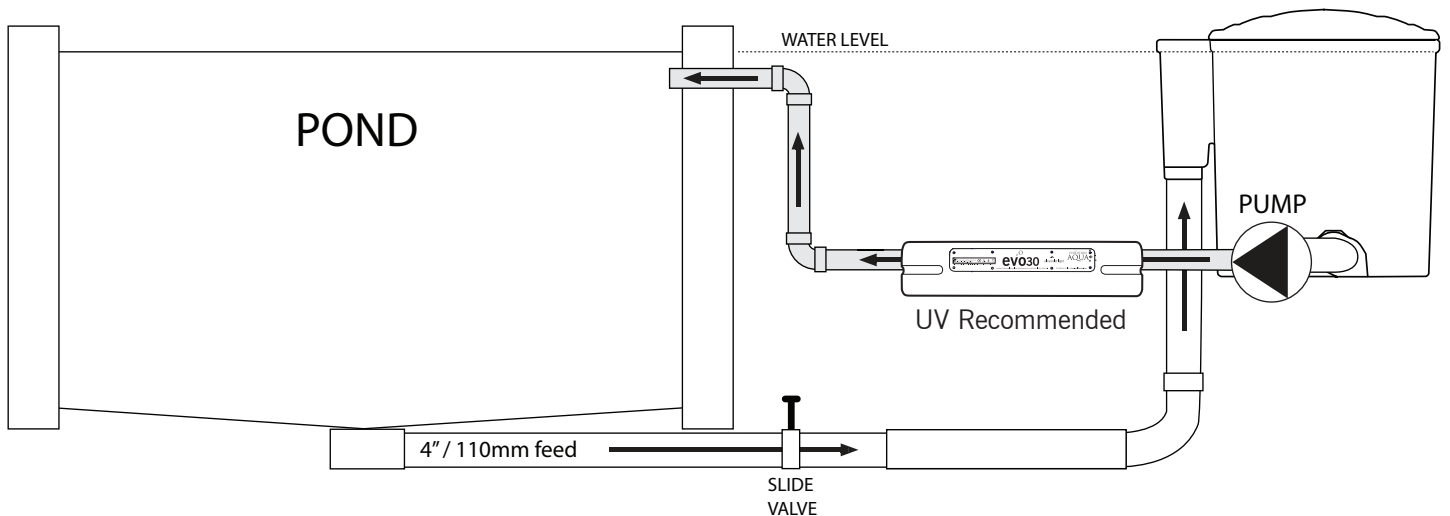

Figure 3. Gravity Fed System (Water gravity fed into Pod and returned to pond by pump)



Please note: The EazyPod comes set up for a pump fed installation.

For installation instructions for Gravity Fed Systems please refer to page 6.

Installation Section (Pump + Gravity Fed)

Preparation

A base with level solid ground is required. It should be a minimum of 600mm x 600mm, to allow easy access to your valves and for maintenance purposes.

Important: The EazyPod filter needs to be supported evenly on a level base (a paving flag is ideal). Failure to do so could cause damage when it is full of water.

Installation Equipment required:

1. **Pond Pump.** Please ensure that the pumps maximum actual flow rate is no more than the specified limits (see page 3).
2. **Air Pump** for cleaning the Kaldnes K1 media. An EA Airpump 70 or 75 is recommended.
3. A length of garden hose or braided pipe (10 mm inner diameter) to connect your air pump to the air ring in the EazyPod.
4. **Tip:** When connecting to your air pump, cut an inch from the airline supplied on the EazyPod. Insert this into the hose pipe that connects to the air pump. This will help maintain the hosepipe's rigidity when inserting it into the rubber connector and clip supplied with your air pump.

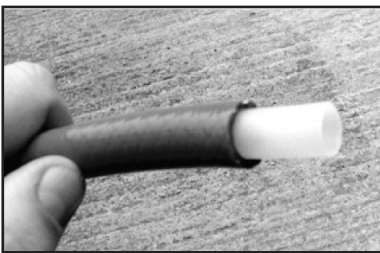

5. **Pipe work** from the unit's waste valves to the intended discharge point. This can be rigid pipe work or a simple flexible hose.

Pump Fed Installation

The EazyPod comes to you ready for a pump fed installation - no changes to any of the fittings are required. See figure 2 for reference diagram.

The unit should be situated at a height above the pond water level, to allow adequate gravity return to the pond (subject to the maximum performance of your chosen pump). The gravity return pipe work from the exit point of the EazyPod to the pond needs to be a minimum of 3 inches (90mm), 4" (110m) for flowrates over 7500 litres per hour and should have no restrictions. Great care should be taken to ensure that no air locks are created within the gravity return pipe work. The return pipe should have an "appropriate fall" from the EazyPod to the pond. The pipe work from the pond pump to the inlet of the EazyPod will need to be connected to the 1.5 inch (50mm) slide valve G. The 4 inch / 90-115 mm (minimum) gravity return pipe work will need to be connected to the rubber adaptor E on the exit point of the Pod. This fitting when first connected to this pipe could appear too big (especially 90mm) or too large 4" (115mm) – it will however reduce/stretch with the clip provided and make a tight seal – this is done with a screwdriver. The return pipe is then extended and returned to the pond or waterfall as required.

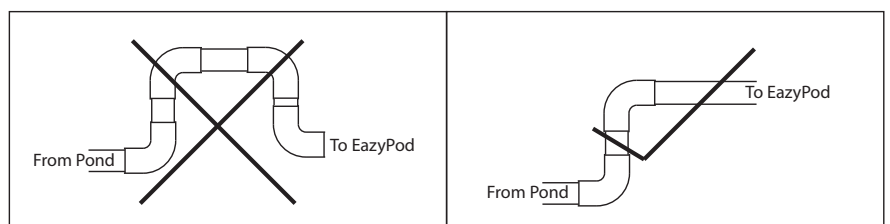

Figure 6

Gravity Fed Installation Section

IMPORTANT...For gravity fed installations, you will need to reverse the exit pipe so that the return pipe D is lower. This is because the exit pipe D although crucial for a pump fed system would impede a gravity unit when the media starts to filter out the debris altering the water level. See figure 3 for reference diagram.

1. Remove the overflow assembly and safely store the 3 screws which secure it (see Fig.7).
2. Remove the stainless steel perforated centre pipe by pulling gently (see Fig.8).
3. Loosen the upper clip on the rubber connector (see Fig. 9)
4. Invert the Pod and remove the 2 screws and plastic pipe support bracket (see Fig. 10)
5. Remove the 90mm return pipe assembly from the EazyPod body (see Fig. 11).

NOTE: The pipe assembly is comprised of 1 long length and 1 short length joined by a 90 bend.

6. Refit the pipe assembly by pushing the shorter end back into the EazyPod, so that the long length is now the exit.
7. Tighten up the rubber connector to form a water tight seal (see Fig. 12).
8. Refit the steel pipe with the perforations at the top, not at the bottom (see Fig. 13).
9. Replace the overflow assembly and rescrew into the housing.
10. Using a hacksaw, cut off the pre-installed inlet (see Fig. 15 and 16).

The Pod must be situated at pond water level. That is to say, that when the circulating pump is switched off, water is level with the overflow assembly. This level will lower when in operation (see Fig. 14 and Fig.6).

The rubber connector on the outlet port must be swapped over so that on the inlet you will have the optional 3 or 4 inch (90-115mm) rubber connector to take your pipe work from the pond and on the outlet you will have the 1.5 inch (50mm) connector for your return pressure line. The slide valve G can be used before your pump, to isolate it, if your pump has a 2½ inlet. The gravity pipework needs to be 4" (110mm) for flows over 7500 litres per hour.

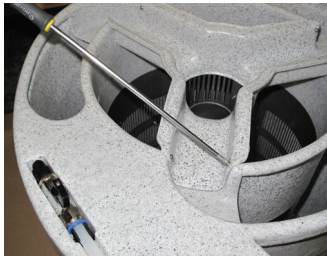

Fig.7A

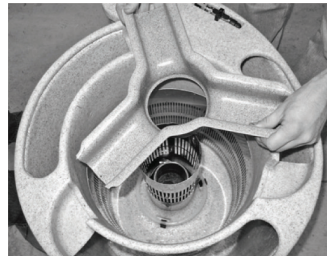

Fig.7B



Fig.8



Fig.9



Fig.10

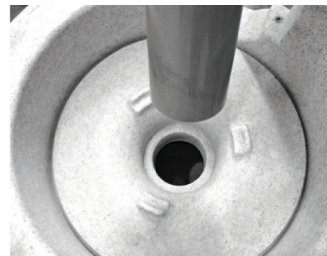

Fig.11



Fig.12

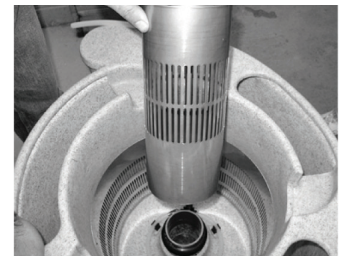

Fig.13

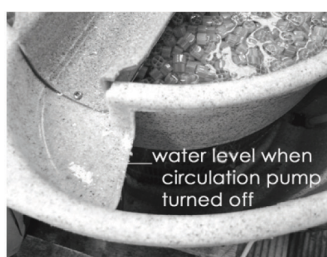

Fig.14

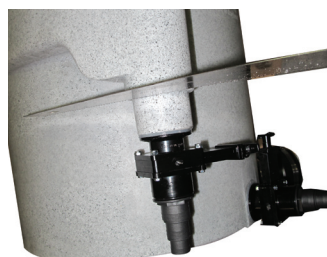

Fig.15



Fig.16

EazyPod Installation & Operating Instructions



Recommendations

It is important be able to isolate the EazyPod for maintenance purposes. Therefore we recommend that you install an isolating valve (3" or 4" inch / 90-115 mm slide or ball valve) on your inlet gravity line before the EazyPod.

Air Pump Installation (Pump + Gravity Fed)

Now that you have your EazyPod installed, you will need to connect your air pump to the EazyPod for the cleaning cycle. This will agitate the K1 so that the waste which has collected in the media can be removed from the system. We recommend an EA Airpump 70 or 75.

The air pump is connected to the air ring inlet using a garden hose or braided pipe (10 mm inner diameter). The air ring inlet is positioned on the outside of the EazyPod. It is recommended that the air pump is positioned higher than the water level in the EazyPod to prevent water flowing back into the air pump when it is switched off. However, the air valve should be in the off position, and the air pump switched off or in use elsewhere when not in the cleaning mode.



Air Valve Off



Air Valve On

Getting Started

Completely empty your bag of K1 into the inner chamber **C**. It is essential NEVER to remove or add any media other than the 30 litres supplied. Cleaning and maintaining the EazyPod will depend on flow rate, feed, stocking, blanket weed etc. An EazyPod on a summer pond with heavy blanket weed will need more frequent maintenance than a pond in December with no food fed. Be aware that any movement of the EazyPod's K1 whilst the pond pump is in operation will dislodge the waste collected and will be sent back to the pond and clarity will suffer. If this does happen, the EazyPod will eventually remove this waste again in time. The cleaning regimes for both pump and gravity installations are listed below.

Please Note A pump fed system will need cleaning when the water level in chamber **B/C** has risen and is close to the overflow assembly. A gravity fed system will need cleaning before the water level in chamber **B** has lowered by 4 inches / 100mm.

System running and maintenance

To achieve optimum water quality and clarity we recommend that the EazyPod be air backwashed and purged on a regular basis. The frequency of cleaning will depend on the loading of the pond. However, the filter must be cleaned regularly. In the event of a blockage, the circulation pump will become starved on a gravity system or the chamber will overflow on a pump fed system. The overflow assembly (on fig 1) is a built in overflow. Should a blockage of the K1 media occur, water will bypass the stainless steel screen and return to the pond.

Cleaning - Pump fed Procedure

1. Insert the cleaning pipe into the plastic return pipe **D**. This will prevent waste going back to the pond and maintain the water level in the Pod whilst cleaning it (see Fig. 17).
2. When the water level in chamber **B** is just level with the overflow assembly, close slide valve **G** on your inlet pressure line. Ensure that this is fully closed as it is essential that this water level is maintained to allow efficient cleaning. If there is insufficient water, the K1 will not agitate and self clean.
3. Switch off the pond pump.
4. Turn on your air pump and open the air valve on the Pod. In a few seconds the K1 media will start to 'agitate' and circulate, thereby self cleaning.
5. After the K1 has been aerated for a minimum of two minutes, open valve **F** and completely drain the EazyPod.
6. Once it is drained, close valve **F**.
7. Open your inlet slide valve **G** and turn on your circulation pump to refill the Pod.
8. When the water level in chamber **B** is just level with the overflow assembly, close the slide valve **G** on your inlet pressure line and switch off the pump.
9. Allow the K1 media to agitate again for a minimum of two minutes.
10. Open valve **F** to drain again. If the water in the Pod is still not 100% clean, repeat the process.
11. Once the K1 is clean, turn off your air pump or re-divert it and close the air valve on the Pod. Close valve **F**.
12. Remove the cleaning pipe.
13. Open inlet slide valve **G**.
14. Start your pond pump and refill the Pod.



Figure 17

Please note that normally 2 cleaning cycles will be needed to completely clean the K1. On a dirty pond, maybe even 3 will be needed. When doing more than one cleaning cycle, there is no need to remove the cleaning pipe and switch the air pump off. Only after the final clean can you switch off the air pump, remove the cleaning pipe and run the EazyPod as normal.

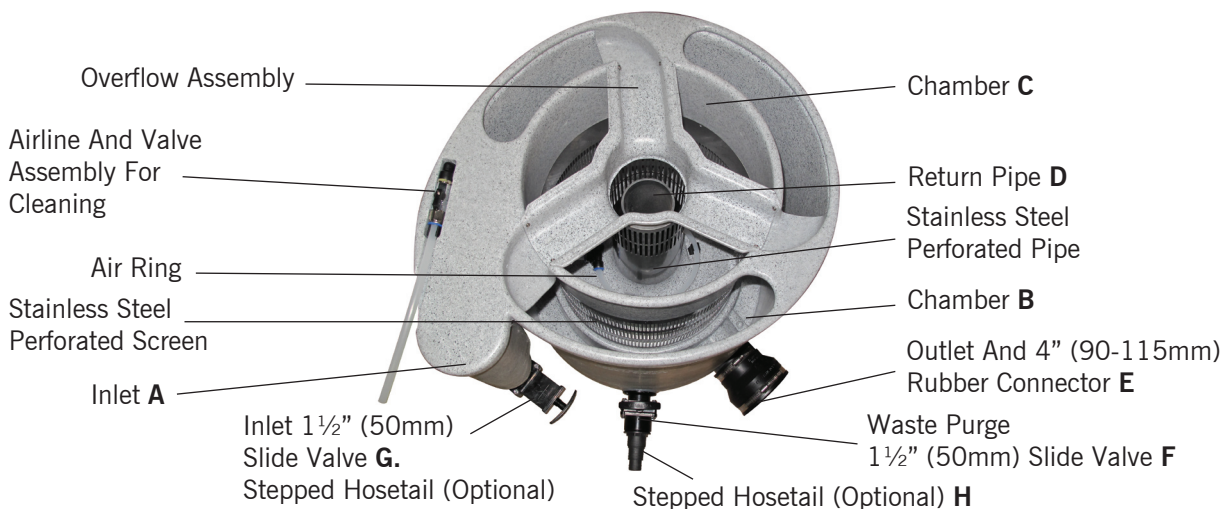

Cleaning – Gravity Fed Procedure

1. Stop the circulation pump.
2. Wait a short period of time to allow the water levels within the Pod to stabilise.
3. Insert the cleaning pipe into the plastic return pipe **D**. This will prevent waste going back to the pond (see Fig. 18).
4. Isolate the pond from the pod by closing the valve on the inlet line.
5. Close the slide valve **G** which you have fitted after your circulating pump.
6. Turn on your air pump and open the air valve on the Pod. In a few seconds the K1 media will start to 'agitate' and circulate, thereby self cleaning.
7. After the K1 has been aerated for a minimum of two minutes, open valve **F** to completely drain the Pod.
8. When drained close valve **F** and open your inlet valve to refill the Pod.
9. Allow the K1 to agitate again for a minimum of two minutes.
10. Open valve **F** to drain again. If the water in the Pod is still not 100% clean, repeat the process.
11. Once the K1 is clean, turn off your air pump or re-divert it and close the air valve on the Pod
12. Remove the cleaning pipe
13. Close valve **F**
14. Open your inlet valve to refill the pod from the pond and start you circulation pump



Figure 18

Please note that normally 2 cleaning cycles will be needed to completely clean the K1. On a dirty pond, maybe even 3 will be needed. When doing more than one cleaning cycle, there is no need to remove the cleaning pipe and switch the air pump off. Only after the final clean can you switch off the air pump, remove the cleaning pipe and run the EazyPod as normal.

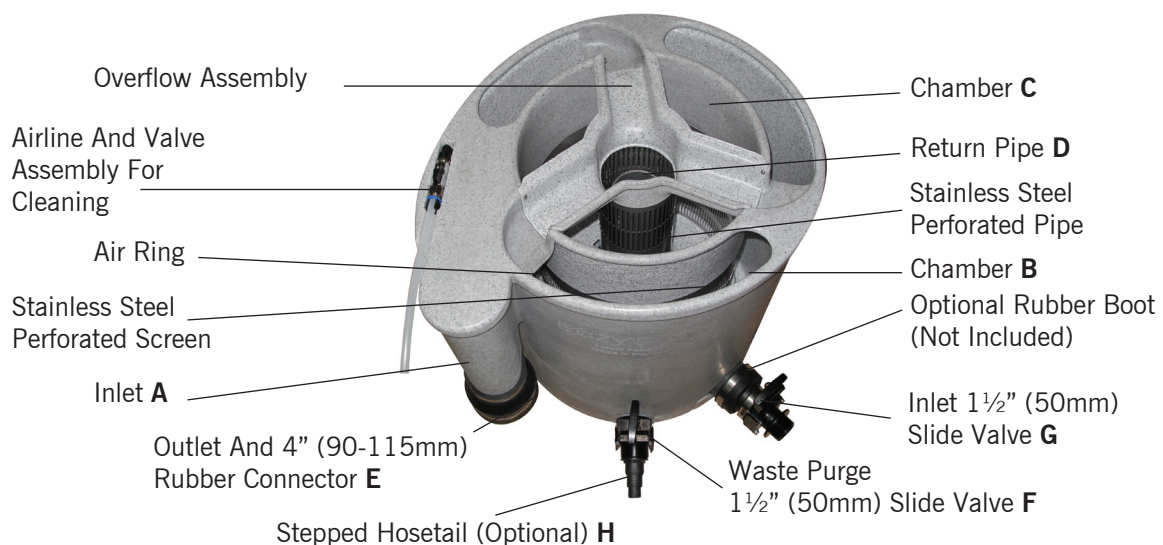

Troubleshooting

Problem	Solution
My K1 stays on the surface of the water and will not sink	The K1 when brand new is buoyant and will want to float on the surface of the water. This is perfectly normal. As soon as fish have been added to the pond it takes the K1 approximately 24 to 48 hours to absorb the water and become semi-buoyant in the EazyPod.
The K1 doesn't move well during the cleaning cycle	The air pump is either not powerful enough or there isn't enough water in the Pod – check that you used the cleaning pipe to maintain the level on a pump fed system. Check all air fittings and line for leaks. Make sure you haven't inadvertently added more K1 than the 30 litres
The pond gets dirty after cleaning	Check that you turned your circulating pump off and that you have used the cleaning pipe, so that the dirt in the K1 hasn't returned to the pond. Please ensure that the EazyPod has gone through a minimum of 2 to 3 cleaning cycles.
Too much maintenance, poor clarity, or Pod overflowing	Make sure that you haven't exceeded the maximum flow rate. Please ensure that the EazyPod has gone through a minimum of 2 to 3 cleaning cycles.

EazyPOD Dimensions

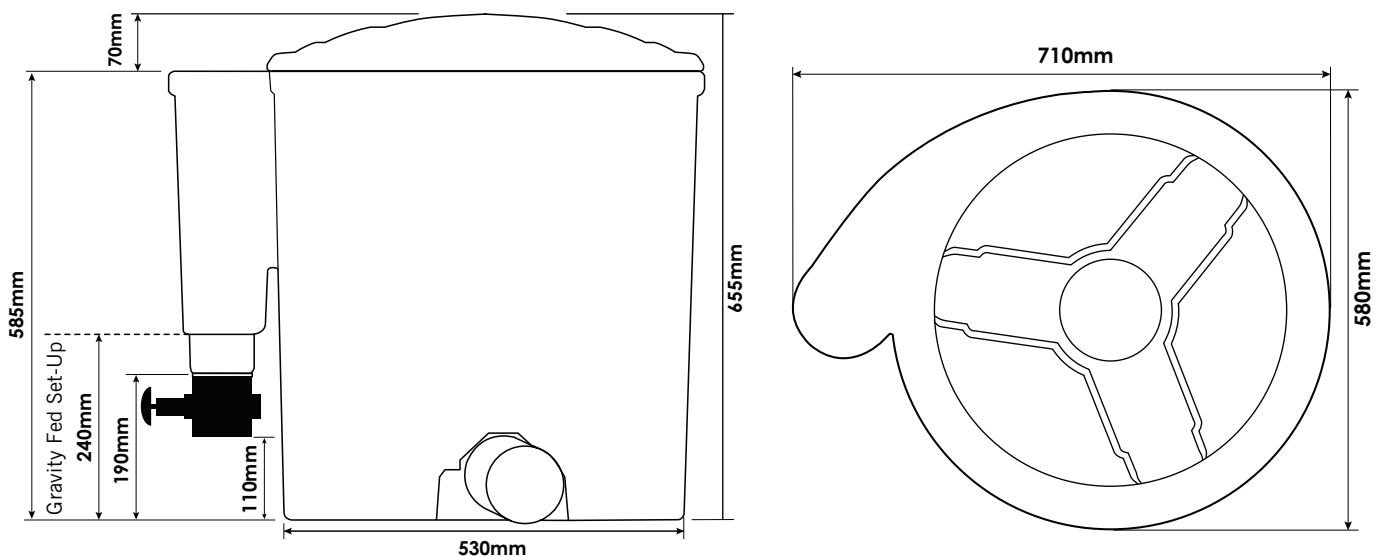

EazyPod Installation & Operating Instructions



Register on our website to get a free monthly newsletter on new products and great pond tips

Distributed by:
Evolution Aqua Ltd
Evolution House, Kellet Close, Wigan, WN5 0LP
United Kingdom.
UK

Sales: +44 (0) 1942 219 898
Technical: +44 (0) 1942 219872

EazyPod Guarantee

This product comes with a 2 year warranty, which is valid from date of purchase. Proof of purchase will be required. Any unauthorised repairs, modifications or alterations to this unit will invalidate the warranty.

Evolution Aqua accepts no responsibility or liability due to accident, improper installation or misuse. Liability is limited to replacement of the defective parts. This guarantee is not transferable. It does not affect your statutory rights.

Evolution Aqua and its dealers shall not be held liable for any loss of fish, plants or any other livestock as a result of any failure or defect of this product.

If there is a warranty issue please contact Evolution Aqua's Technical Service department.
Claims for transport damage shall only be recognized if the damage is reported within 24 hours after delivery and confirmed by the carrier.

Evolution Aqua reserve the right to change this product specification without prior notice.

All products designed to ISO 9001 and manufactured to ISO 9000
Patent Information: GB2.293333B; WO/00 61258; PCT/GB01/05533; PCT/GB01/05549; 0750591;
0575314; 5,543,039; 5,458,779; 6126829; 689246; 2119893; 3183406

eatips

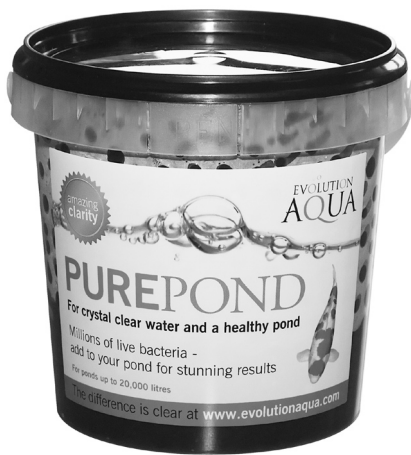

For optimum performance use Evolution Aqua's **PURE POND** to mature the EazyPod and for general maintenance.

evouV
ultraviolet light



Use the EazyPod in conjunction with an Evolution Aqua **evouV** for prevention of green water (single cell algae).

pH

Maintaining the pH level of the pond water above 7 will allow the friendly filter bacteria in the EazyPod to flourish.

detoxTM



Water changes via an Evolution Aqua **Detox Dechlorinator**.